

EXPLODED VIEW
12ST / 12ST FS
Version 3.0 Version 1.0.F

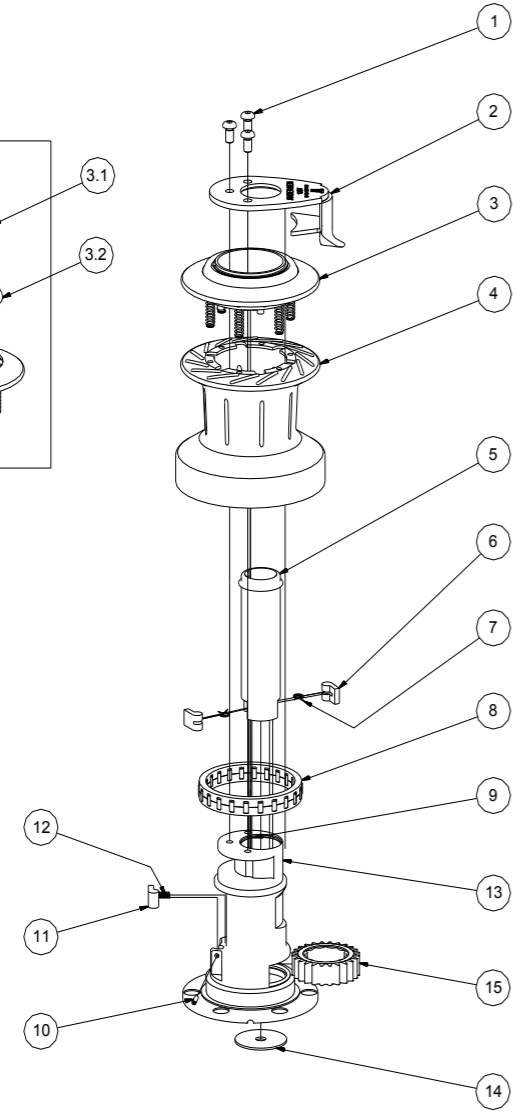
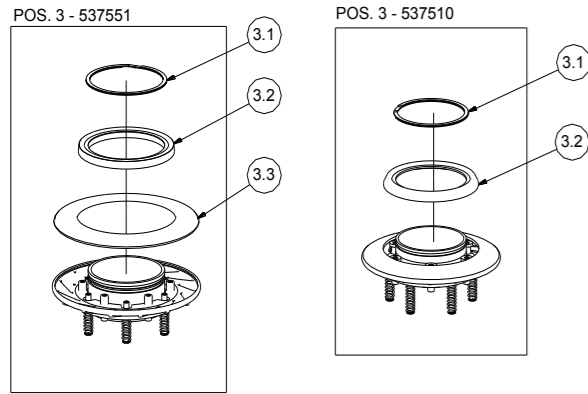

PARTS LIST
12ST / 12ST FS
Version 3.0 Version 1.0.F

POS.	QTY.	DESCRIPTION	ART. NO.
1	3	Screws	ISO 7380-A4-M6x12
2	1	Self-tailing arm	596711
3	1	Self-tailing top	Model ST - 537551 / ST FS - 537510
3.1	1	Circlip	726400U
3.2	1	Top ring	782100
3.3	1	Disc	Model ST – 537550 only - 726310
4	1	Drum complete	726811
5	1	Drive shaft complete	726703
6	2	Pawl	713200
7	2	Arm spring	713300
8	1	Roller Bearing	727400
9	2	Bushing	<i>Not removable</i> 716501
10	1	Screw	DIN 913-A4-M4X12
11	1	Pawl	533400
12	1	Spring	533500
13	1	Base	731710
14	1	Insert Plate	727500
15	1	Ratchet gear	711701
1	1	Service kit	710018

MOUNTING INSTRUCTION
12ST / 12ST FS
Version 3.0 Version 1.0.F

Installing the winch is easy, if you follow these instructions. The numbers in () refer to the position numbers in the parts list.

Tools required for the installation:
Screwdriver (large).
Ø6,5 mm. (1/4") drill.
6 pcs. M6 (1/4") countersunk head screws.
Ring spanner to match nuts.

1. Remove screws (1).
2. Remove selftailing arm (2) and drum (4).
3. Mark location of bolt holes using the template.
IMPORTANT: On this model the selftailing arm (2) is fixed in one position. Ensure correct positioning of the selftailing arm, before marking and drilling the bolt holes.
4. Remove base (13). Be sure that no dust comes into contact with the winch while drilling.
5. Drill bolt holes Ø6,5mm (1/4").
6. Apply a light coat of bedding compound, ensuring that each bolt hole is bedded. Keep drain grooves clear.
7. Fasten base (13) into place using 6 pcs. M6 (1/4") countersunk head screws. Use large washers or a backing plate.
8. Assemble in reverse order.
9. Check that the winch is functioning correctly:
The drum should operate smoothly, by turning the drum clockwise by hand.
The drum must not turn when trying to turn the drum anti clockwise.
While turning the winch handle clockwise the drum should turn.
While turning the winch handle anti clockwise the drum should not turn.

SERVICE INSTRUCTION
12ST / 12ST FS
Version 3.0 Version 1.0.F

Tools required for service:
Screwdriver (large).
Screwdriver (small).
Winch handle.

1. Remove screws (1).
2. Remove self-tailing arm (2) and drum (4).
3. Insert a winch handle. Pull up the drive shaft (5) gently, while turning ratchet gear (15) carefully. Remove drive shaft (5).
4. Remove pawls (6) and arm springs (7).
5. Remove ratchet gear (15). DO NOT remove the insert plate (14) but make sure that the insert plate is positioned in its groove.
6. To release the roller bearing (8), gently insert a small screwdriver between roller bearing and base (13).
7. Remove roller bearing. Remove spring (12). DO NOT remove the pawl (11) and the spring (12) on the base.
8. Clean all parts in petrol. Remember to clean the gear teeth and roller bearing track.
9. Assemble in reverse order. During assemble, lightly grease all gear teeth, drive shaft, roller bearing, shafts, balls, pawls, springs and bushings. Use a small, soft brush. Pawls may be lubricated with either a very thin film of ANDERSEN WINCH GREASE. It is very important that pawls can move freely.

IMPORTANT: When assembling the winch, check the functioning of each pawl by pushing the pawl against the spring. The pawls should move smoothly and automatically return to their normal position, where the pawls engage with the teeth. If the pawls do not function correctly, clean and lubricate the pawls and gears. Check the function of the pawls again to make sure that it works correctly. If the pawls do not work correctly replace the springs and recheck the functioning.
Not properly functioning pawls may lead to unexpected release of the winch force resulting in fatal injuries to the user and others.

Service Kit No: 1 (art. no. 710018) contains spare parts for this winch.

IMPORTANT INFORMATION

ALL WINCHES



Read All Safety Notices and Product Manuals

Do not install or operate this winch before reading and fully understanding the contents of this Safety Notice Sheet and the Product Manual.



Stay Alert When Operating

Andersen winches are very powerful and have the potential to cause significant damage and/or serious injury if used improperly or without due caution and vigilance.



Operators Must Be Trained

Help prevent significant damage and/or serious injury by ensuring any person operating a winch has a thorough understanding of its proper operation and is aware of the potential hazards involved. As a minimum, all winch operators must read and understand this Safety Notice Sheet and the Product Manual.

Particular attention is drawn to the following points:

- Children and others not qualified to operate an electric winch must be kept at a safe distance from the winch and any rigging or fittings that are under load.
- Long hair and/or loose clothing must be tied back to avoid being caught in the winch.
- In the event of a rope override or other fault, stop the winch and turn off power before attempting to resolve the problem.



Avoid Accidental Operation

Remove winch handles and turn off power to the winch when not in use to help avoid unsupervised or unintentional operation. Failure to do so could result in significant damage and/or serious injury.



Maintenance

Turn off power to the winch before performing any maintenance or service tasks. Failure to do so could result in significant damage and/or serious injury.



Lifting Operations

The winch must not be operated with the rope in the self tailer when used in any kind of lifting operation.

Any lifting operations should be conducted by two persons in order to maintain constant visual contact with the object being lifted.

Furthermore the selftailer must not be used as a cleat for a rope used to lift or suspend any object. The rope must be secured properly by tying off, or leading to a suitable fitting such as a cleat or bollard.

Failure to observe these precautions could result in serious injury or death.

DO NOT DISCARD

5. februar 2013 — Part no.: 710212

WARRANTY

Refer to our website www.ronstan.com/warranty for our warranty terms and conditions

WORLD WIDE DISTRIBUTION & SERVICE

VISIT WWW.ANDERSENWINCHES.COM



Manufactured by: Ronstan Denmark ApS. - Jægersvænget 36 - 7100 Vejle - Denmark
info@andersenwinches - www.andersenwinches.com

Manual

12ST / 12ST FS

Version 3.0 Version 1.0.F



GENERAL INFORMATION

Due to the best choice of materials and high precision in manufacturing, we recommend, for normal use, only to dismantle, clean and lubricate the winch once every second year. Under extensive use, such as racing, charter or blue water sailing, we recommend to lubricate the winch once every year. We strongly recommend always to use ANDERSEN WINCH GREASE, when lubricating your winch. ANDERSEN WINCH GREASE is a high quality silicone/Teflon grease product. Most other types of grease, including "marine grease" are not suitable for lubrication of winches. Non-suitable grease products can cause malfunction, which could result in fatal injuries for the user and others. Pawl arm springs should be replaced every second year. Spare arm springs and other parts that may be required are included in the ANDERSEN Service Kit. Please refer to the service instruction for the Service Kit suitable for the specific winch. When the winch handle is not in use but the winch is under load, we recommend, from a safety point of view, to remove the winch handle from the winch. To ensure correct function of the selftailing unit, only use recommended line sizes. When using the winch with mooring lines DO NOT use the selftailing function and be sure that the mooring line is not in contact with the selftailing arm.

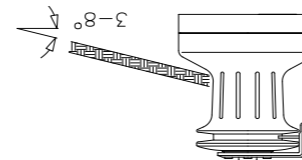

To ensure the best possible functioning of the winch, we recommend that the winch is placed in accordance with the line entry shown below.

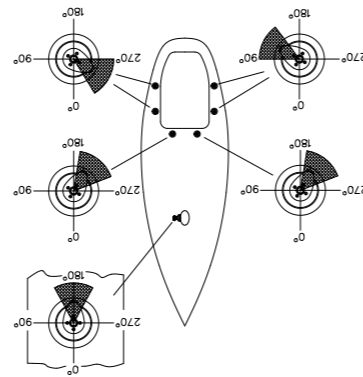

Be also aware that selftailing arm is positioned correctly. We recommend to have the selftailing arm positioned within the shaded area. On 12ST and 28ST the position of the selftailing arm is fixed, making it very important to establish the proper location of the holes prior to drilling these in the deck. On all other models, the selftailing arm can be placed in several different positions after having installed the winch.

PAWL SPRING MOUNTING

Note the curved spring "arm"

